

# Dual Smart Card Terminal Controller

## For e-Transaction, Control Access and Advanced Smart Card Reader Applications



The 73S1121F is the industry's first extensive low-cost system-on-a-chip smart-card terminal controller. It is also the most complete member of Teridian's 73S11xx IC family.

This single chip smart-card reader includes all the features required to build a low-cost smart-card terminal in a single package. Based on an 80C52 core, with two built-in smart card interfaces, communication capabilities and peripherals, the 73S1121F device is dedicated for low-cost hand held terminals.

The 73S1121F can also be used in complex architectures, as a secondary microcontroller dedicated to smart card management. Its dual card interface makes it ideal for use in conjunction with a SAM (Secure Access Module), where high level of security is required. For additional security, the 73S1121F is also available in die form to allow Chip-on-Board tamper-resistant implementations.

The embedded flash memory of the 73S1121F can be downloaded through the serial interface, either initiated from the external world by hardware (In-System-Programming mode, or ISP, controlled by a dedicated input), or from the embedded application (In-Application-Programming, or IAP). IAP can therefore support update of the flash memory through the USB. ISP mode can be used at production level to download the first application, and can be permanently disabled by blowing a built-in fuse. This will guarantee the integrity of the embedded application, and only the embedded application itself will be able to update the contents of the flash memory.

To support the 73S1121F hardware, Teridian Semiconductor Corp. has developed a comprehensive software suite (library software in ANSI-C) that implements two-level Application Programming Interface (API). The low level API provides drivers for the embedded peripherals and the high level API includes protocol layers to communicate with asynchronous cards (protocols T=0 and T=1, compliant with ISO-7816 and EMV-4.0) and with the USB interface. It also provides services for PIN management, memory management and display. In addition, a ready-to-use EMV test application is available which can be immediately incorporated into custom projects, to allow immediate EMV certification in accredited labs. Use of these proven software layers will reduce the development time of 73S1121F-based products, which means dramatic improvement in time-to-market. The development of the embedded application can be done using the API in conjunction with the 73S1121F Development Toolkit, and with emulation tools and C-development environments, as described in the 73S1121F Development Toolkit Product Brief.

### Key Applications

- *PC-connected PIN-pad Terminals for:*
  - *E-Banking*
  - *Secure Login and Logical Access*
  - *Government ID*
  - *e-Purse*
- *Payment and Transaction Terminals*
- *General Purpose Smart Card Readers*

### Key Advantages

- *A unique dual smart card reader with USB connectivity*
- *Available in die form for very low-cost applications*
- *Software API (libraries in C) includes the ready-to-use protocol layers for EMV level 1, USB and more*
  - *Faster development and certifications*
  - *Time-to-market*
- *CCID reference design with optional driver*



**TERIDIAN**  
SEMICONDUCTOR CORP.  
A FORMER TDK GROUP COMPANY

## Features

### Microcontroller

- 80C52 Core
- 64KB internal Flash (Program Memory)
- 4KB internal XRAM (User Data Memory), expandable to 64KB
- ROM Boot-loader enabling In-System Programming (ISP) and In-Application Programming (IAP) of the internal Flash
- External memory interface that can be used for applications that require more than 64KB of program space, or permanently disabled
- 128 Bytes Flash IFB (Information Block for serial #, firmware version...)
- Single low cost 12MHz crystal
- Optional 32kHz crystal (with internal counter for real time clock support)

### Smart Card Interfaces

- (2) ISO-7816 / EMV4.0 smart card interfaces w/ embedded Step-up converter for 3V/5V smart-cards
- ISO-7816 UART (9600Kbps to 115Kbps with 12MHz crystal) for protocols T=0, T=1 with (2) dedicated 2-Byte FIFOs
- Auxiliary I/O lines for C4/C8 signals and UART bypass for synchronous card support
- Card clock stop high and low
- Card clock up to 7.2MHz
- Shared 4-wire interface enabling connection of up to 7 external SAMs

### Peripherals

- 5x6 Keyboard interface with hardware scanning, de-bouncing and scrambling
- (7) Dedicated LCD I/Os (to control any external LCD driver)
- 8) User I/Os
- 4) GPIOs compatible with interfacing voltages up to 5.5V
- 8) Analog inputs for voltage detection (for battery monitoring or any DC voltage comparison from 0.2V to 2.5V)

## 73S1121F Block Diagram

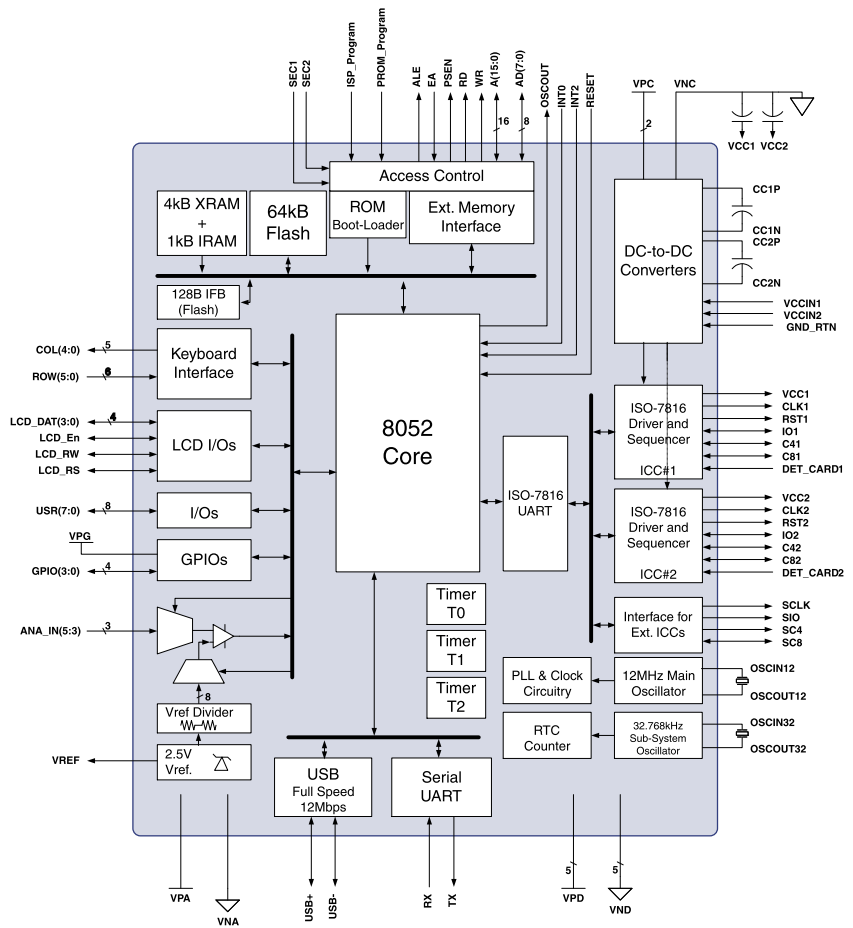

**Power Supply:** Single 2.7V to 3.6V

**Package:** 128 pin TQFP and Die form

### Security

- Embedded fuses allow designers to permanently disable access to the embedded Flash memory, the external memory interface, the In-System Programming (ISP) mode or any combination of the three.

### Communication

- USB Full-speed interface (12Mbps with 4 Endpoints)
- (1) Serial interface 1200Kbps to 115Kbps (Standard 8052 serial UART)

### Software

- Two-level API (C-language libraries) for fast application development
- CCID Reference design, compatible with Microsoft CCID driver, and with Teridian CCID driver, that supports PINpad, LCD and multi card slots



6440 Oak Canyon, Irvine, CA 92618-5201  
714-508-8800 (Tel)  
714-508-8878 (Fax)

For immediate technical information and the name of a local representative or distributor, visit [www.teridian.com](http://www.teridian.com), send an e-mail to [support@teridian.com](mailto:support@teridian.com) or call (714) 508-8800.

No responsibility is assumed by Teridian Semiconductor Corporation for use of this product nor for any infringements of patents and trademarks or other rights of third parties resulting from its use. No license is granted under any patents, patent rights or trademarks of Teridian Semiconductor Corporation, and the company reserves the right to make changes in specifications at any time without notice. Accordingly, the reader is cautioned to verify that the data sheet is current before placing orders.