

0,50mm HEADER BTH SERIES

SPECIFICATIONS

Materials:

Insulator Material:
Liquid Crystal Polymer
Terminal Material:
Phosphor Bronze
Current Rating:
Testing Now!
Plating:
Au over 50µ" (1,27µm) Ni

Mates with:
BSH

Note: Some lengths, styles and options are non-standard, non-returnable.

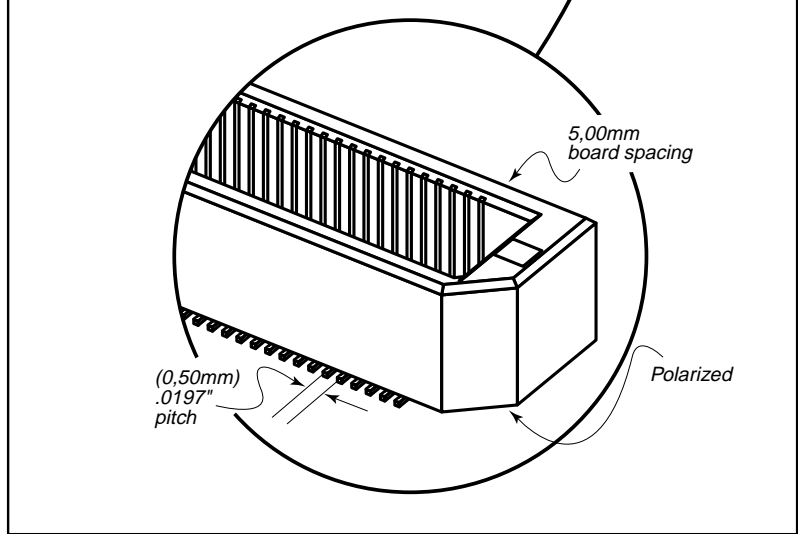

Processing:

Max Processing Temp:
230°C for 60 seconds
SMT Lead Coplanarity:
(0,10mm).004" max
Suggested PCB Layouts:
Your specific layout may vary

