

A Versatile Step-Up and Step-down Converter Design Using AIC1628

Ben Tai

The AIC1628 step-up DC/DC Converter can achieve very high efficiency in various applications, especially for +12V flash memory programming voltage and color LCD contrast bias control voltage applications; the efficiency of these application can reach as high as 85% to 95%.

The greatest concern in systems using battery power is the power conversion efficiency. High efficiency converters can not only provide good power conversion efficiency at normal operation, but also reduce its own current consumption during idle time. In order to maintain good conversion efficiency from light to full loads, the AIC1628 uses the intermittent switching control method named PFM (Pulse-Frequency Modulation) rather than the conventional PWM control method. Fig. 1 shows the IC's basic function block. When the feedback voltage is great than the reference voltage, the drive output is 0V. When the feedback voltage is lower than the reference voltage, the oscillator starting output and send signal to the driver. This kind of control method works similar to PWM at full load, with a stable switch waveform; while light load it uses intermittent switching to efficiently sustain output loading requirements.

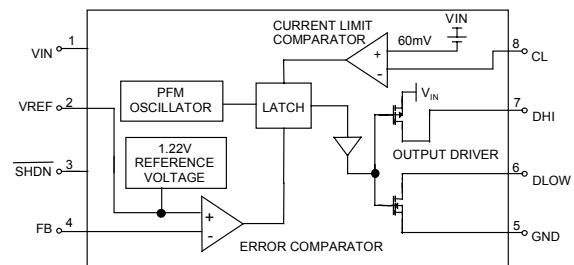

Fig. 1 AIC1628 Function Block

In addition, the AIC1628 converter has the following features:

1. Able to operate under input voltage range from 4V to 24V.
2. Output voltage can be adjusted externally.
3. It has a PFM design adjusting switching frequency and duty cycle automatically, which makes it possible to obtain highly efficient conversion over a wide input and output voltage range.
4. Build in shutdown mode control.
5. Works in high frequency range from 90KHz to 250KHz, hence only requires small size inductor.
6. It has complementary push-pull output driver, is able to drive either NPN transistor or MOSFET.
7. Low cost.

Some application examples are explained below. The circuit shown in Fig. 2 is a power supply

design for color LCD brightness contrast bias control. When V_{IN} is higher than 7V, a high efficiency of 93% can be obtained at full load. The input power can come directly from a battery or the main power source without requiring secondary conversion. At the same time it also provides higher gate drive voltage to the MOSFET, this result the reducing of MOSFET's Switch ON resistance, and hence reduces the conduction loss directly. All of these factors contribute to the high conversion efficiency. If an NPN is used for lower cost consideration, efficiency may be decreased about 2% to 5%.

The circuit shown in Fig. 3 provides a +12V output for flash memory programming power. The efficiency is always in the range of 90% to 95% when V_{IN} is in the range from 5V to 11V and the load is larger than 60mA condition. In other applications where battery voltage is lower than 5V, the AIC1628 can be configured as the circuit shown in Fig. 4. Note that the AIC1628 itself is powered by a 5V main power assumed available. In this way, it is easier to drive a MOSFET to obtain a higher efficiency. If cost reduce are required, the MOSFET can be replaced by an NPN transistor. Efficiency, however, will also be reduced by about 2% to 5%.

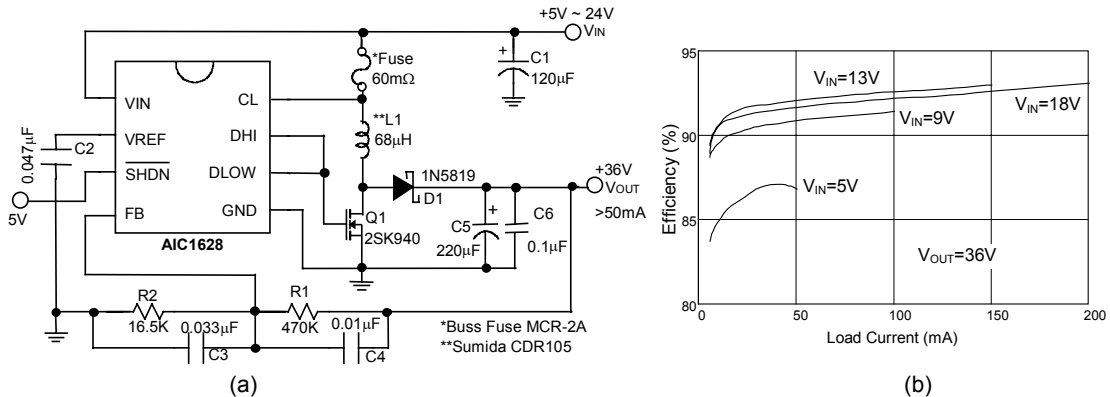

Fig. 2 LCD Contrast Bias Application
(a) Application Circuit
(b) Efficiency vs. Load Current

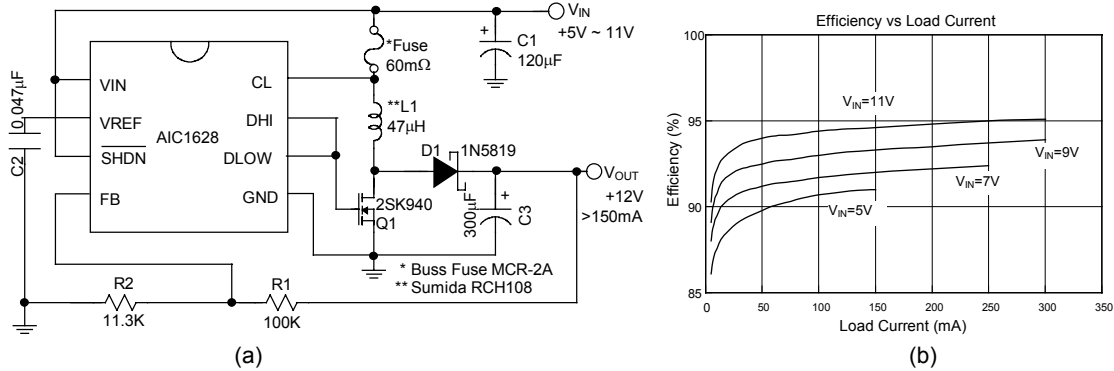

Fig. 3 Flash Memory Programming Power
(a) Application Circuit
(b) Efficiency vs. Load Current

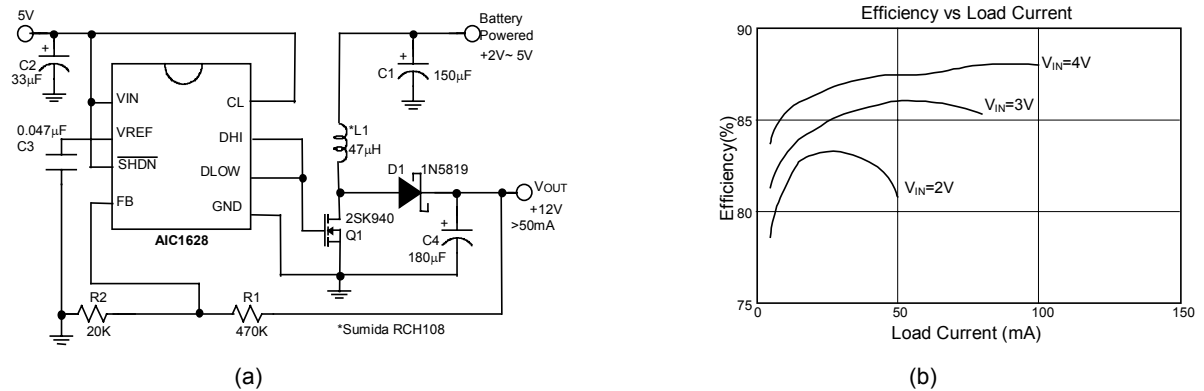
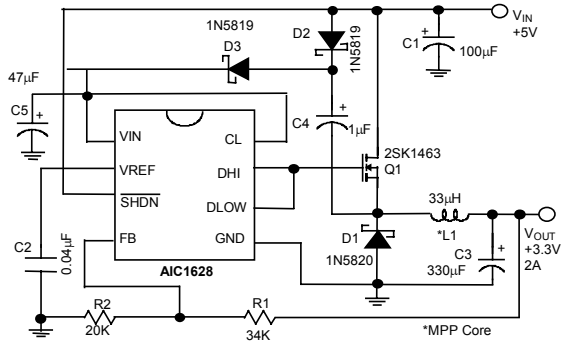

Fig. 4 2 Cells to 12V Step-Up Power Supply
(a) Application Circuit
(b) Efficiency vs. Load Current

Fig. 5 is a circuit configuration of a high efficiency step-down DC/DC converter, providing a conversion from 5V to 3.3V at 2A output loading. A charge pump circuit is used to generate a $2 \times V_{IN}$ voltage for the AIC1628 to drive an N-MOSFET. The advantages of using N-MOSFET include lower cost and higher efficiency than P-channel

counterpart. Typically, a 50mΩ $R_{DS(ON)}$ ($V_{GS} = 5V$) MOSFET with an MPP core can deliver 2A output current and efficiency can exceed 92% at 1A loading. Higher output driving capability mandates lower $R_{DS(ON)}$ of N-MOSFET and lower V_F of Schottky diode.



(a)

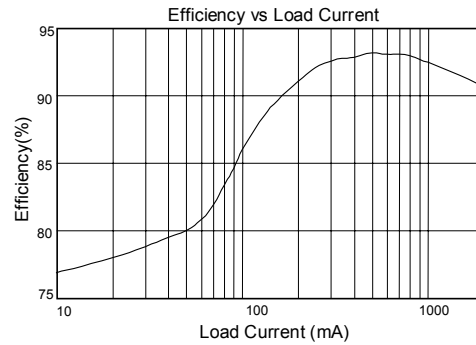

(b)

Fig. 5 5V to 3.3V Step-Down Converter

(a) Application Circuit

(b) Efficiency vs. Load Current